

ROTER

RECYCLING



SHEAR **RX550/770/990**
BALER





RX550/770/990

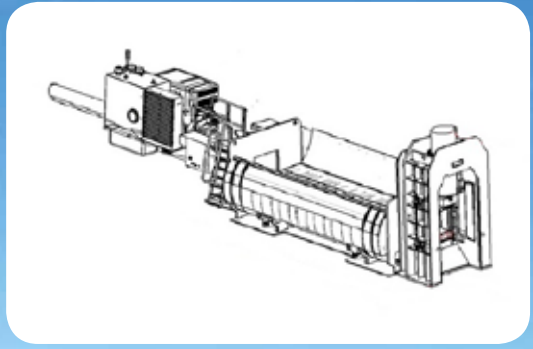

ROTER

UNIQUE ADVANTAGES OF SHEAR SERIE "RX"

- Our machines are built for tough working conditions.
- Very long life span.
- Industrial, robust and flexible design.
- Able to process a wide range of metals and steels.
- Easy loading material.
- Top quality components to ensure long-term profitability.
- Fast and efficient after-sales service.
- All spare parts available in stock.
- This semi-mobile machine doesn't need foundation.
- The installation is very fast and the plant is ready to work in only few hours.
- 100% developed trouble shooting assistance system.
- Every component is easy accessible for maintenance.
- Extremely customizable according to the production needs of the scrap yard.
- The Programmable Logic Controller (PLC) is protected from power surges through a stabilized power supply in order to avoid sudden changes in voltage coming from the battery.
- The machine is equipped with Safety Engine Auto Stop in case of malfunctions or alarm situations that could compromise the safety to the operator or the equipment.
- The machine is equipped with an alarm auto diagnostic system and guided procedures which constantly monitor the state of the machine and allow the operator to maintain control of the machine functions and the active alarms.

WORKING PROGRAMS

- Dense Bale
- Bale for Mills
- Shear
- Shear with pre-compression

STANDARD FEATURES

Main Pump	Parker PV Plus Series
Diesel Engine	Perkins Power Pack
PLC	Siemens S7-300
HMI	Touch Screen 7"
Remote control	Autec MJ Series

OPTIONALS

Electric motor 2 x 90 kW (2 x 125 kW)	EM
Hydraulic lifting legs (*)	LL
Preload table	PT
Protection main cylinder	PC
Cabin for operator	OC
Cabin heating	CH
Cabin air conditioner	CC
Preheating Hydraulic Oil	OH
Preheating engine	EH
Customized colour	CCL
Manuals in different language	CM
Emergency spare parts kit	KE
2000 hours spare parts kit	2000K

(*)Not available for RX990

TECHNICAL DATA

	RX550.6	RX770.6	RX770.7	RX990.7	RX990.8	
Shear force	550	750	750	990	990	tons
Hold-down force	100	100	100	100	100	tons
Box material	HARDOX 400/450					
Box length	6.000	6.000	7.000	7.000	8.000	mm.
Opened box width	2450	2540	2540	2640	2640	mm.
Cylinders per lid	2	2	3	3	3	
Lids force	210	210	315	315	315	tons
Main cylinder force	155	155	155	155	155	tons
Bale size	800 x 600	800 x 600	800 x 600	900 x 600	900 x 600	mm.
Oil circuit capacity	1500	2500	2500	3000	3000	Lt.
Diesel tank capacity	250	250	250	400	400	Lt.
Engine power	225/168	250/186	250/186	276/205	276/205	HP/KW
Shear lubrication	AUTOMATIC					
Hold down lubrication	AUTOMATIC					
Cuts per minute	3,5 - 4	3,5 - 4	3,5 - 4	3,5 - 4	3,5 - 4	
Min cutting length	150	150	150	150	150	mm
Working pressure	280/320	280/320	280/320	280/320	280/320	bar

ROTER

RECYCLING

ROTER s.p.a.

Sede Amministrativa e Stabilimento:

Via Fontanella, 2 - 44035

FORMIGNANA (FE) - ITALY

TEL.: +39 0533 608911

www.roter-recycling.com

info@roter-recycling.com



ISO 14001 cert n. 11543



IO Net is member of:

C.REV.01

Distributed by: